

SCHEDA TECNICA / SPECIFICATIONS

Art. AH77LED5

SPECCHIO INGRANDITORE A PARTETE CON LUCE A LED, A BATTERIA INGRANDIMENTO x5 WALL MOUNTED MAGNYFING MIRROR WITH LED LIGHT, WITH BATTERY, ENLARGEMENT x5

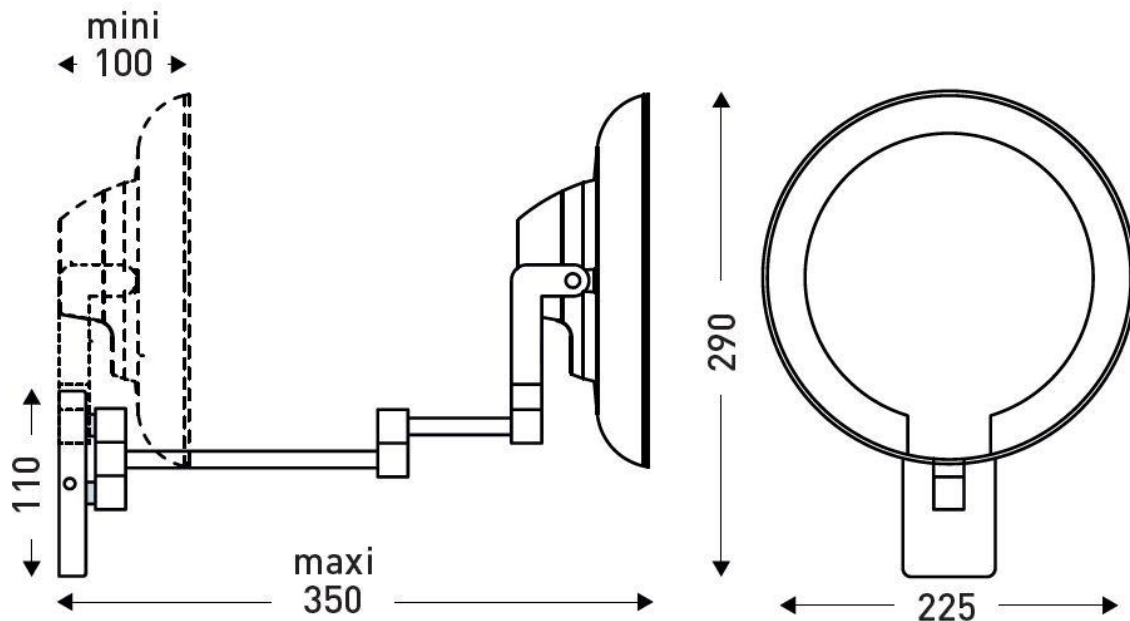

- Senza collegamento elettrico (funziona con una batteria al litio (dura \pm 3 anni a seconda dell'uso)
- Accensione con sensore
- Diametro specchio \varnothing cm 22
- Ingrandimento x 5
- Timer: 3 minuti
- Braccio in ottone cromato tubolare, 4 posizioni, misure: L.225 x A.290 x P.350 mm
- Piastra a muro in ottone cromato, misure: L.55 x A.110 x P.18 mm
- Without electrical connection (it works with a lithium battery (lasts \pm 3 years a depending on use)
- Ignition with sensor
- Mirror diameter \varnothing cm 22
- Magnification x 5
- Timer: 3 minutes
- Tubular arm in chromed brass, 4 positions, measurements: L.225 x H.290 x P.350 mm
- Wall plate in chromed brass, measurements: L.55 x H.110 x P.18 mm

