

**SCHEMA TECNICA / SPECIFICATIONS**

Art./item **AH92ST**



- Asciugacapelli con supporto da parete, corpo in ABS bianco con finitura cromata.
- 2 regolazioni di velocità.
- Bassa rumorosità di funzionamento e ottimo flusso d'aria calda che consente un'asciugatura veloce.
- Sistema di autoprotezione contro il surriscaldamento.
- Interruttore di sicurezza On / Off sulla base a muro.
- Installazione Zona 3 del bagno.
- Cavo spiralato flessibile tra asciugacapelli e base a muro, lunghezza 60/120 cm.
- Cavo lineare di alimentazione lunghezza 90 cm.
- Viti per fissaggio in dotazione.



- Sèche-cheveux blanc en ABS – fixation murale – finition chromée.
- Moteur silencieux. Excellent flux d'air chaud pour un séchage rapide.
- Interrupteur à deux positions de débit d'air.
- Système d'auto protection contre la surchauffe.
- Interrupteur marche / arrêt sur la base murale.
- Installation en zone 3 de la saie de bain.
- Câble à spirale entre support mural sèche-cheveux, longueur 60/120 cm.
- Câble linéaire d'alimentation longueur 90 cm.
- Vis de fixation incluses.



- White ABS wall-mounted hair dryer with chrome plating.
- Quiet, long-life motor and excellent warm air flow that allows a quick drying.
- Slide switch: Two air flows settings.
- Self-protection system against overheating.
- On / Off switch on wall base.
- Installation zone 3 of bathroom.
- Spiral cord between hair dryer and wall base length 60/120 cm.
- Power supply cable length 90 cm.
- Fixing screw included.



Funzionamento:	Pulsante a rilascio di sicurezza
Grado di protezione elettrica:	CLASS II (doppio isolamento)
Tensione di alimentazione:	220 V – 240 V
Frequenza:	50 - 60 Hz
Potenza:	2 regolazioni max. 1200 W
Peso:	700 gr.

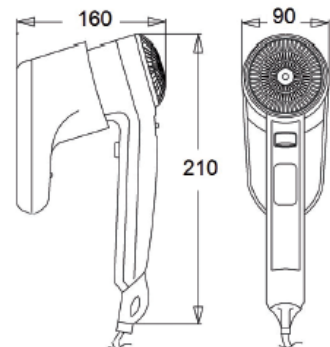

Activation:	Bouton-poussoir de sécurité
Isolation électrique:	CLASS II (double isolation)
Tension d'alimentation:	220 V – 240 V
Fréquence:	50 - 60 Hz
Puissance:	2 positions max. 1200 W
Poids:	700 gr.



Functioning:	Push / release button
Electrical insulation:	CLASS II (double insulation)
Power supply:	220 V – 240 V
Frequency:	50 - 60 Hz
Wattage:	2 setting max. 1200 W
Weight:	700 gr.